

番号	訂正事項	年月日	担当
△			
△			

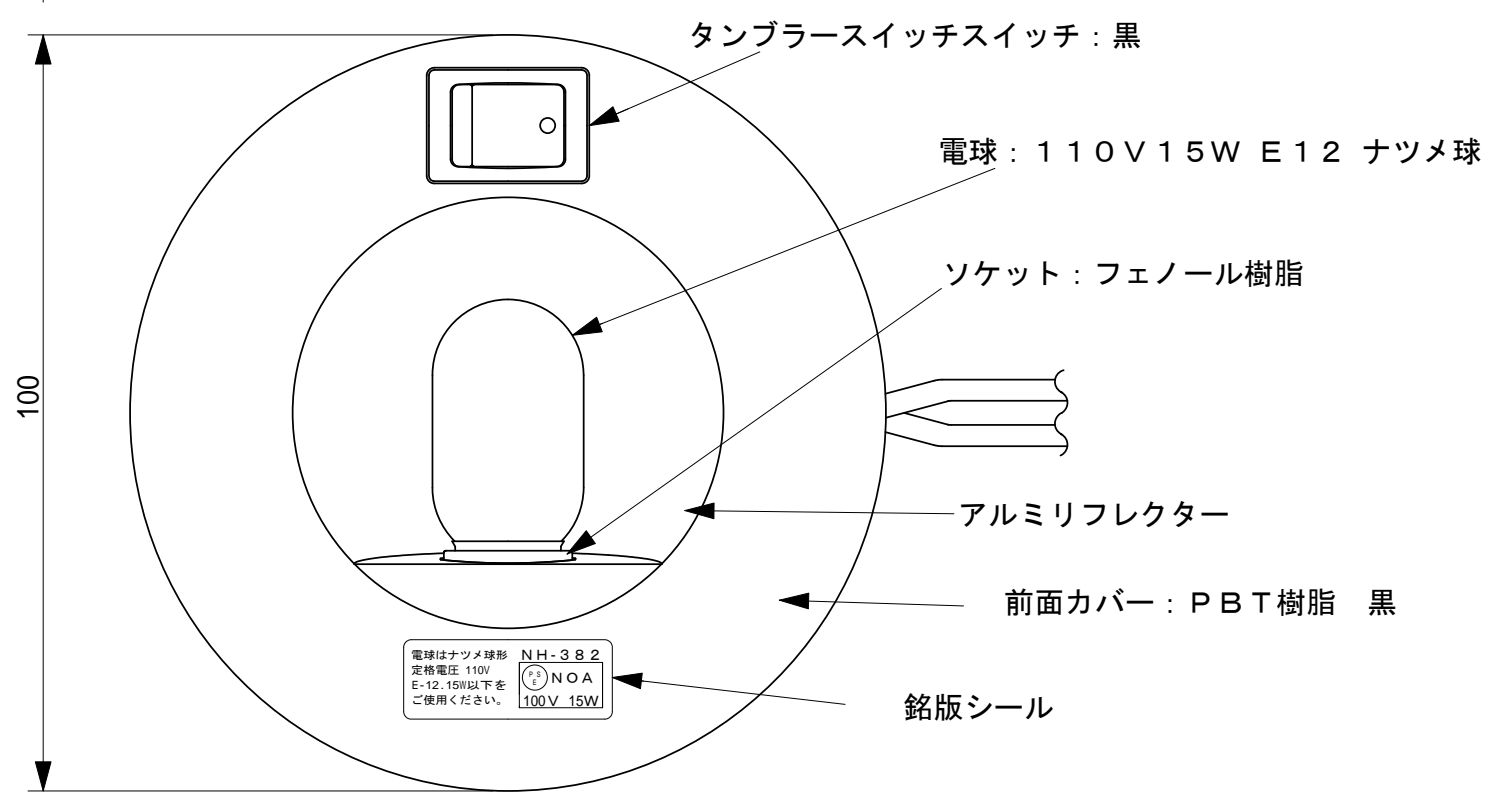
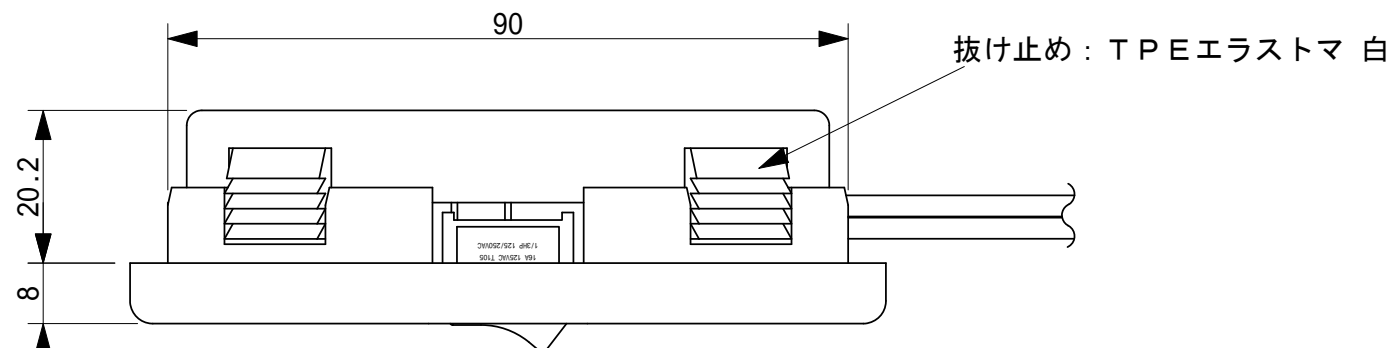
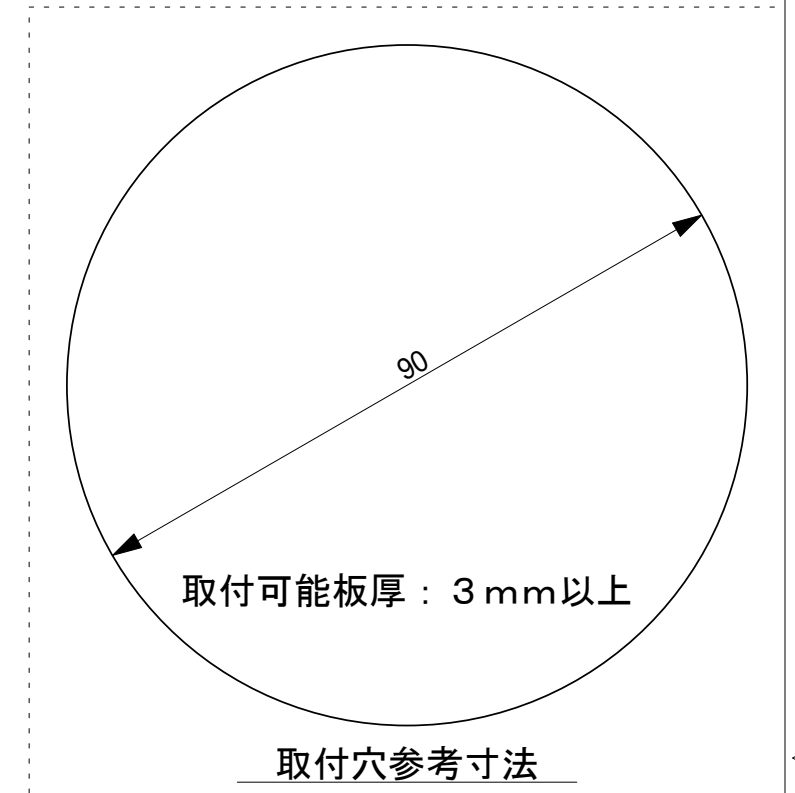
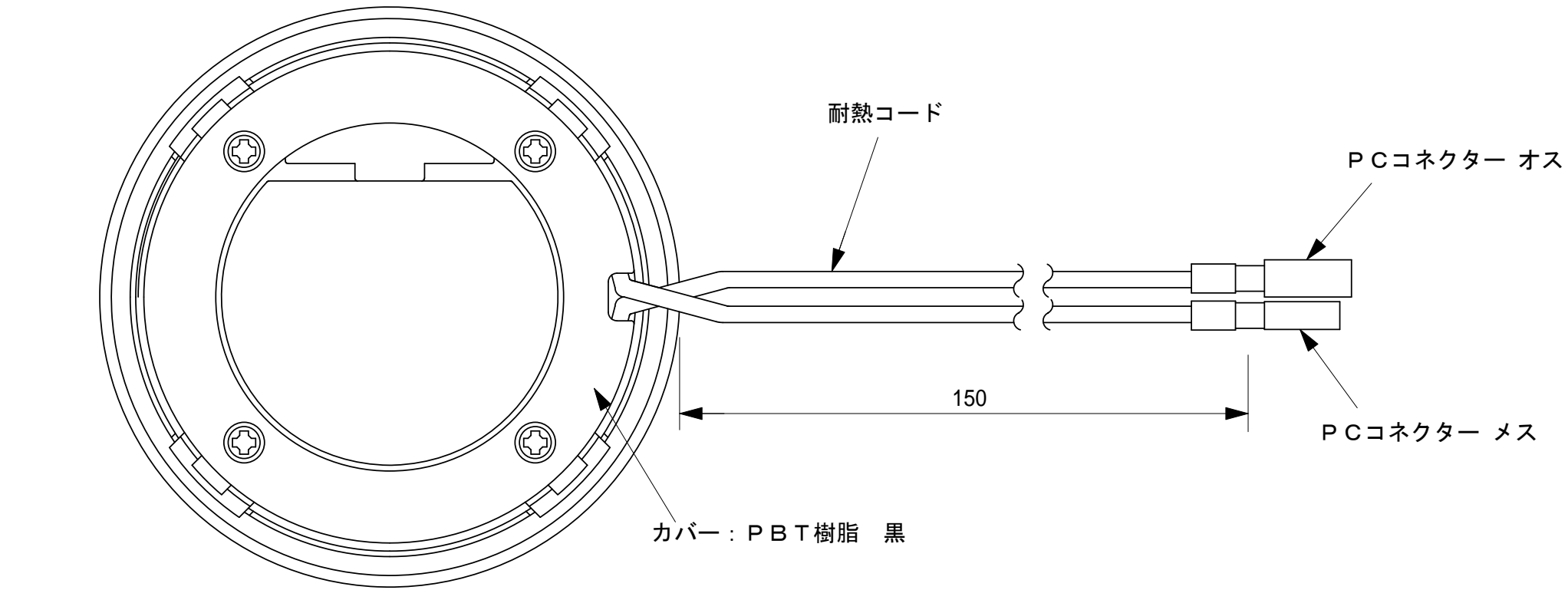

尺 度	1 / 1	製 図 亀山	検 図	承 認	件 名 図 番	NH-382
	単位 mm/mm					12.08.02